

The image features a teal background with a pattern of white dots. The dots are arranged to form a large, stylized shape that resembles a lowercase letter 'r' or a similar form. The dots are of uniform size and are spaced out to create a textured, dotted effect. The word "rainjet" is written in a white, lowercase, serif font, positioned in the lower right quadrant of the image. A small trademark symbol (TM) is located at the end of the word.

*rainjet*TM

customer care number

As part of Rexair's Customer Care program, each RainJet receives a Customer Care serial number only after passing Quality Control assurance testing. This serial number provides:

- ✓ Ownership identification for you
- ✓ Assurance of passing Quality Control testing
- ✓ Warranty identification for your Distributor
- ✓ Assurance of "factory-fresh" condition

For future reference, record the serial number in the space provided below. No authentic, new RainJet should be sold without this number. If the serial number is missing, Rexair makes no claim as to the origin, age, or condition of the unit. If you are unable to locate a serial number on your RainJet, please contact Rexair's customer service department.



50 W. Big Beaver Road, Suite 350 | Troy, Michigan 48084 | USA
(248) 643-7222 | custserv@rexairllc.com
rainbowsystem.com

Rainbow®, RainbowMate®, RainMate®, AquaMate®, Rexair®, The Power of Water®, Wet Dust Can't Fly® and the configuration of the Rainbow® Cleaning System are registered trademarks of Rexair LLC, Troy, Michigan, United States.

RAINJET SERIAL NUMBER

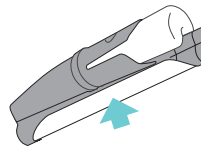

YOUR AUTHORIZED RAINBOW DISTRIBUTOR

NAME	
ADDRESS	
CITY/STATE/POSTAL	
PHONE	
E-MAIL	

Contact your local Authorized Rainbow Distributor for advice on caring for your RainJet, warranty coverage, replacement parts and service information.

important safety instructions



PLEASE READ ALL INSTRUCTIONS BEFORE USING THIS UNIT

When using an electrical appliance, basic precautions should always be followed, including the following:

⚠ WARNING: TO REDUCE RISK OF FIRE, ELECTRICAL SHOCK OR INJURY

1. Do not leave appliance when plugged in. Unplug from outlet when not in use and before servicing.
2. To reduce the risk of electrical shock, use indoors only.
3. To avoid risk of electrical shock and to reduce risk of fire, use only Rainbow cleaning products intended for use with this machine.
4. To avoid risk of electrical shock, use only the hose supplied with the Rainbow for wet pickup operations. See Rainbow owner's manual. Do not modify the electrified plug in any way.
5. The RainJet contains an electric motor and power cord. To avoid risk of electrical shock, DO NOT immerse the electric cord in water while filling or cleaning the tank.

⚠ IMPORTANT

6. The RainJet tank is designed to use only Rainbow *Clean Floor* solution and clean, cold tap water. To avoid damage to the RainJet, do not place any of the following into the water tank:
 - Hot water or liquids
 - Commercially available cleaning liquids or compounds
7. Do not use on hardwood or laminate flooring.
8. Do not use the RainJet when the water tank is empty. This could result in damage to the pump.
9. Do not immerse Squeegee in liquids.
10. For further safety instructions, refer to Rainbow Owner's Manual.

SERVICING OF DOUBLE-INSULATED APPLIANCE

In a double-insulated appliance, two systems of insulation are provided instead of grounding. No grounding means is provided on a double-insulated appliance, nor should a means for grounding be added to the appliance. Servicing a double-insulated appliance requires extreme care and knowledge of the system and should be done only by qualified Rainbow service personnel. Replacement parts for a double-insulated appliance must be identical to the parts they replace. A double-insulated appliance is marked with the words "DOUBLE-INSULATION" or "DOUBLE-INSULATED." The Symbol (square within a square) may also be marked on the appliance. Any servicing other than cleaning should be performed by an Authorized Rainbow Distributor or Service Center.



**SAVE THESE
INSTRUCTIONS**

THIS APPLIANCE IS INTENDED FOR HOUSEHOLD USE ONLY
USE THE RAINJET ONLY AS DIRECTED IN THIS OWNER'S MANUAL
USE THE RAINJET WITH MODEL E2 RAINBOW ONLY

get acquainted with your rainjet™

1. Floor Squeegee & Sponge
2. Floor Squeegee & Brush
3. RainJet Body
4. RainJet Tank
5. Stainless Steel Wand*
6. Rainbow Hose*
7. Rainbow*
8. Rainbow Dolly & Water Basin*
9. Clean Floor Solution

*Not included

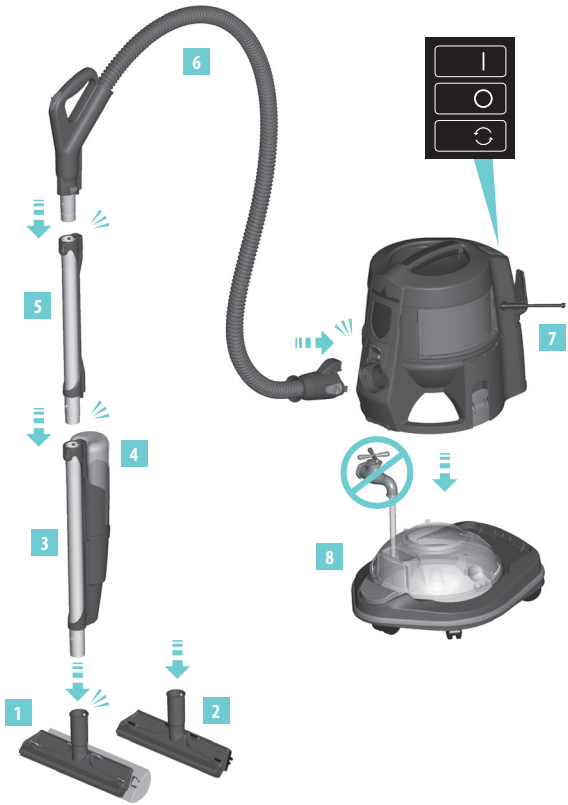

STORAGE & MAINTENANCE

- a. Remove Squeegee head from wand. Rinse in warm water until clean.
- b. Remove excess remaining water from sponge by vacuuming the sponge with the Rainbow hose.
- c. Store and allow to dry.

quick-start guide

1. Prepare the floor...

- a. Use the Rainbow to vacuum the entire area to be cleaned, making sure there is no remaining debris on the surface.
- b. Empty and rinse the water basin. Do not refill.

2. Prepare the RainJet...

- a. Begin with an empty water basin. Attach the Rainbow and dolly. Attach the hose and wands.
- b. To soften sponge, dampen with water before using.
- c. Insert the bottom wand with male end into the opening located on top of the RainJet. Press downward until button lock clicks.
- d. Measure one capful of Rainbow *Clean Floor* solution and add to the RainJet tank.
- e. Fill the remainder of the RainJet tank with cool, clean tap water and secure the cap tightly.
- f. Insert the RainJet tank into the RainJet body until you hear it lock into place.

3. Clean...

- a. Turn the Rainbow on high mode.
- b. Squeeze the pistol trigger grip and apply solution to the floor. Use the sponge or brush to clean the floor with forward and backward movements.
- c. To pick up liquid, use the squeegee blade and pull backward.
- d. When finished cleaning, empty and rinse the water basin. Allow to dry.
- e. Rinse the RainJet tank with cool, clean tap water. Allow to dry.

frequently asked questions

Is the RainJet safe to use on my floors?

The RainJet cleans the following types of floors: marble, stone, ceramic tiles and vinyl and linoleum. Do not use on unfinished, oiled or waxed wooden boards, unsealed tiles, or carpeted floors because they may be water-sensitive. If you have any doubts about the safety of Rainbow *Clean Floor* solution on your flooring, place a small amount of solution on a small, inconspicuous portion of the floor. When completely dry, check for a small white circle, which indicates the floor has a wax or oil finish and should not be cleaned with the RainJet. Remove the white circle by reapplying a small amount of wax finish and buffing. On floors periodically cleaned with wax or shine-enhancing products, the RainJet may remove the shine from the floor.

Is the RainJet safe to use around pets?

Yes, when using the recommended one capful, the Rainbow *Clean Floor* solution is not harmful to pets.

Where can I have my RainJet serviced or purchase extra *Clean Floor* solution?

This Rainbow appliance has been thoroughly tested and inspected. For service matters, or to purchase replacement parts or extra *Clean Floor* solution, please contact your local Authorized Rainbow Distributor. If you are unable to contact the Distributor from which you purchased the appliance, visit rainbowsystem.com to locate a nearby Authorized Rainbow Distributor.

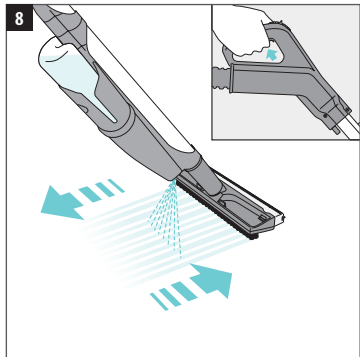
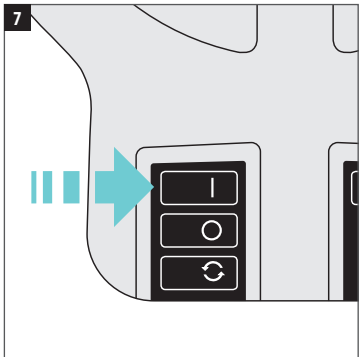
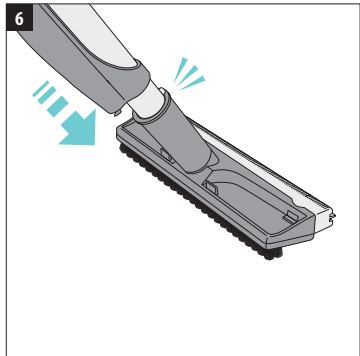
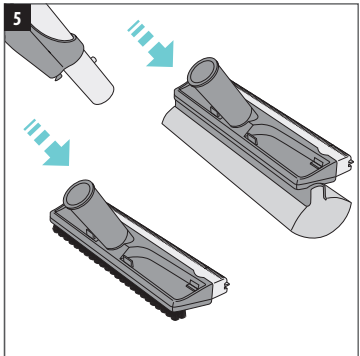
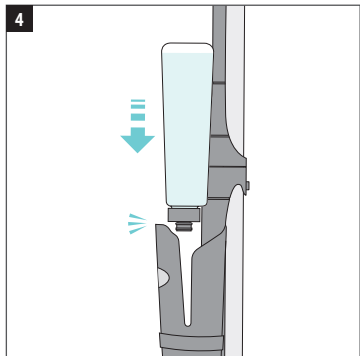
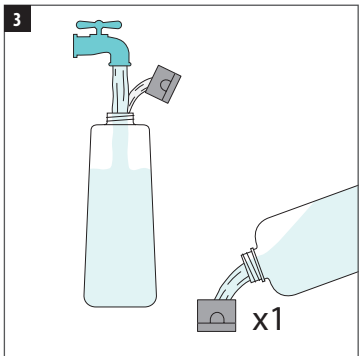
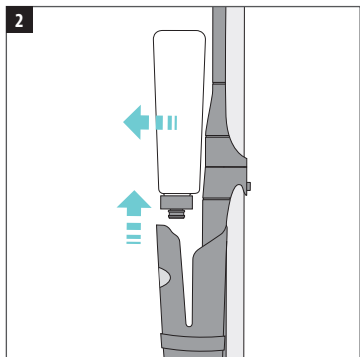
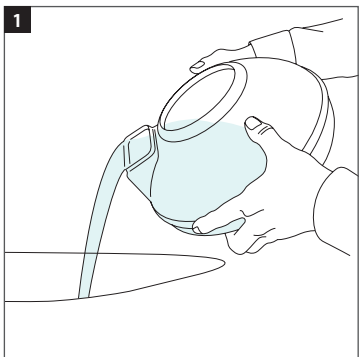

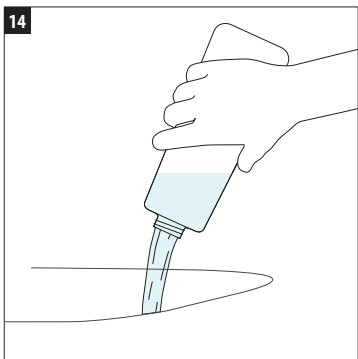
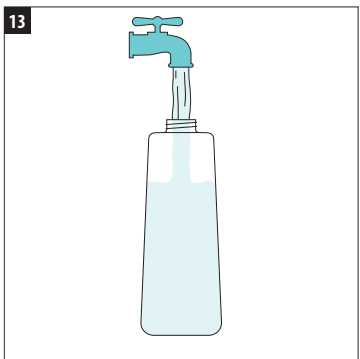
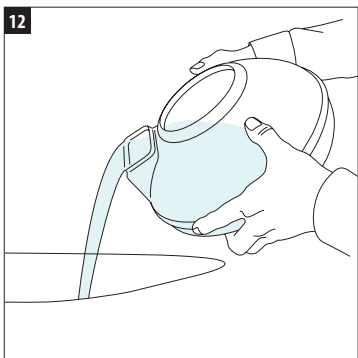
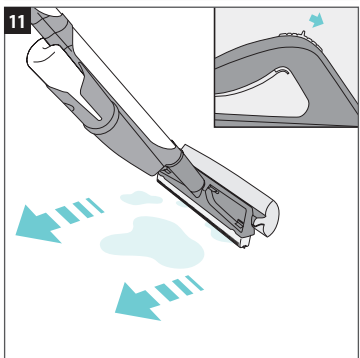
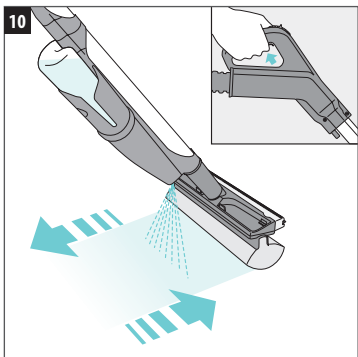
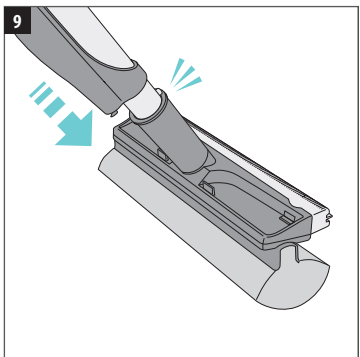

rainbowsystem.com

REXAIR LLC | TROY, MICHIGAN

© 2011 REXAIR LLC | R14116A-1 | PRINTED IN U.S.A.

